



Sub218

Dual 18 inch Direct-Radiating Subwoofer

VLF Install



Overview

The Sub218 is an all-purpose, dual 18 inch, vented subwoofer that is designed to provide extended low frequency support in a wide variety of installations. Its premium, high power transducers are physically engaging, yet are musically articulate enough to reproduce the subtlety and harmonic nuance of an upright bass or the low strings of a piano.

The Sub218 requires digital signal processing, and many platforms are supported. The Sub218 is an excellent option any time a subwoofer with robust SPL capability is needed. This makes it the perfect choice for large houses of worship or theatres, live reinforcement or dance systems, high intensity DJ monitors, A/V screening rooms, and distributed low frequency reinforcement in nightclubs and theme parks.

Technologies

The two 18 inch woofers in the Sub218 have high power, 4 inch voice coils, and are capable of impressively large excursion. The enclosure is optimally tuned to provide maximum low frequency output.

Performance Specifications¹

Operating Mode

Single-amplified w/ DSP

Operating Range²

25 Hz to 154 Hz

Nominal Beamwidth

Spherical within operating range

Transducers

LF: 2x 18.0" woofers, 4.0" voice coil; ceramic magnet

Power Handling @ Nominal Impedance³

98 V / 2400 W @ 4 Ω (2x 1200 W @ 8 Ω)

Nominal Sensitivity @ Input Voltage⁴ (half / whole space)

104 dB / 98 dB @ 2.00 V

Nominal Maximum Continuous SPL (half / whole space)

144dB / 138 dB peak
138 dB / 132 dB continuous

Equalized Sensitivity @ Input Voltage⁵ (half / whole space)

101 dB / 95 dB @ 2.00 V

Equalized Maximum SPL⁶ (half / whole space)

141 dB / 135 dB peak
135 dB / 129 dB continuous

Recommended Power Amplifier

2400 W to 3600 W @ 4 Ω

Physical Specifications

Connections

(2) Neutrik NL4 Speakon

Pin 1+/-: LF1

Pin 2+/-: LF2

Mounting / Suspension Points

(16) M10 eye bolt angle points

Dimensions / Weight

See page 4

Finish

Black painted enclosure w/ matte black grille, or
White painted enclosure w/ matte white grille

Options

Terminal strip input, Custom color finish



product specification

Axial Sensitivity (dB SPL, 2.00V @ 1 m, half space)^{7,8}

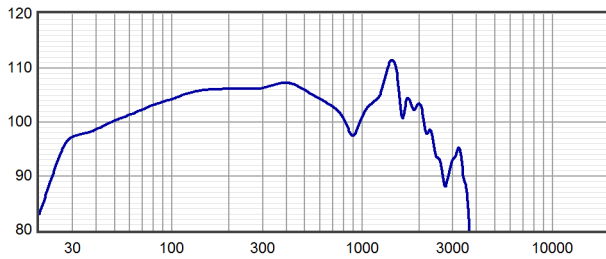

Axial Processed Response (dB, half space)^{7,9}

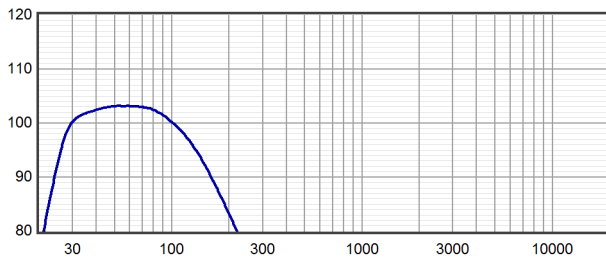

Impedance (ohms)

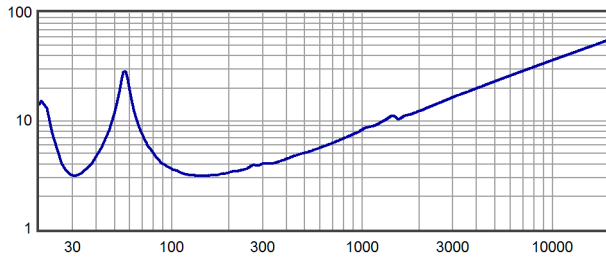



Connection Diagram

1-way, Single-Amp

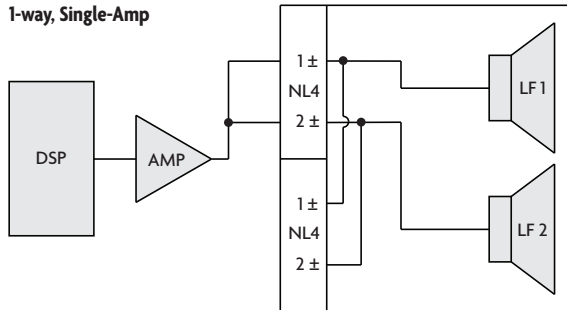

1-way, Dual-Amp

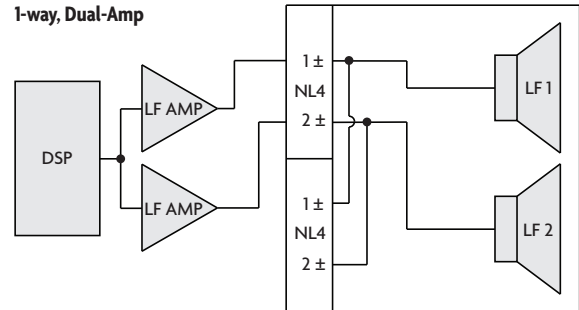

Mechanical Specification Drawings

2D and 3D DXF dimensional drawings are available for download at www.fulcrum-acoustic.com/support.

Notes

¹ **Performance Specifications** All acoustic specifications rounded to nearest whole number. External DSP with Fulcrum Acoustic-provided settings is required to achieve the specified performance.

² **Operating Range** The frequency range within which the processed response is within 10 dB of the average.

³ **Power Handling** Based on the AES power handling of the transducers.

⁴ **Nominal Sensitivity** The 1-meter-referenced SPL produced by a 1 watt band limited pink noise signal, with no processing applied.

⁵ **Equalized Sensitivity** The 1-meter-referenced SPL produced when an EIA-426-B signal is applied to an equalized loudspeaker system, at a level which produces a total power of 1 watt, in sum, to the loudspeaker subsections.

⁶ **Equalized Maximum SPL** The 1-meter-referenced SPL produced when an EIA-426-B signal is applied to an equalized loudspeaker system, at a level which drives at least one subsection to its rated power.

⁷ **Resolution** All response graphs are subjected to 1/6 octave cepstral smoothing with a gaussian weighting function.

⁸ **Axial Sensitivity** The SPL plotted against frequency for a 1 watt swept sine wave, referenced to 1 m with no signal processing.

⁹ **Axial Processed Response** The axial magnitude response with recommended signal processing applied.

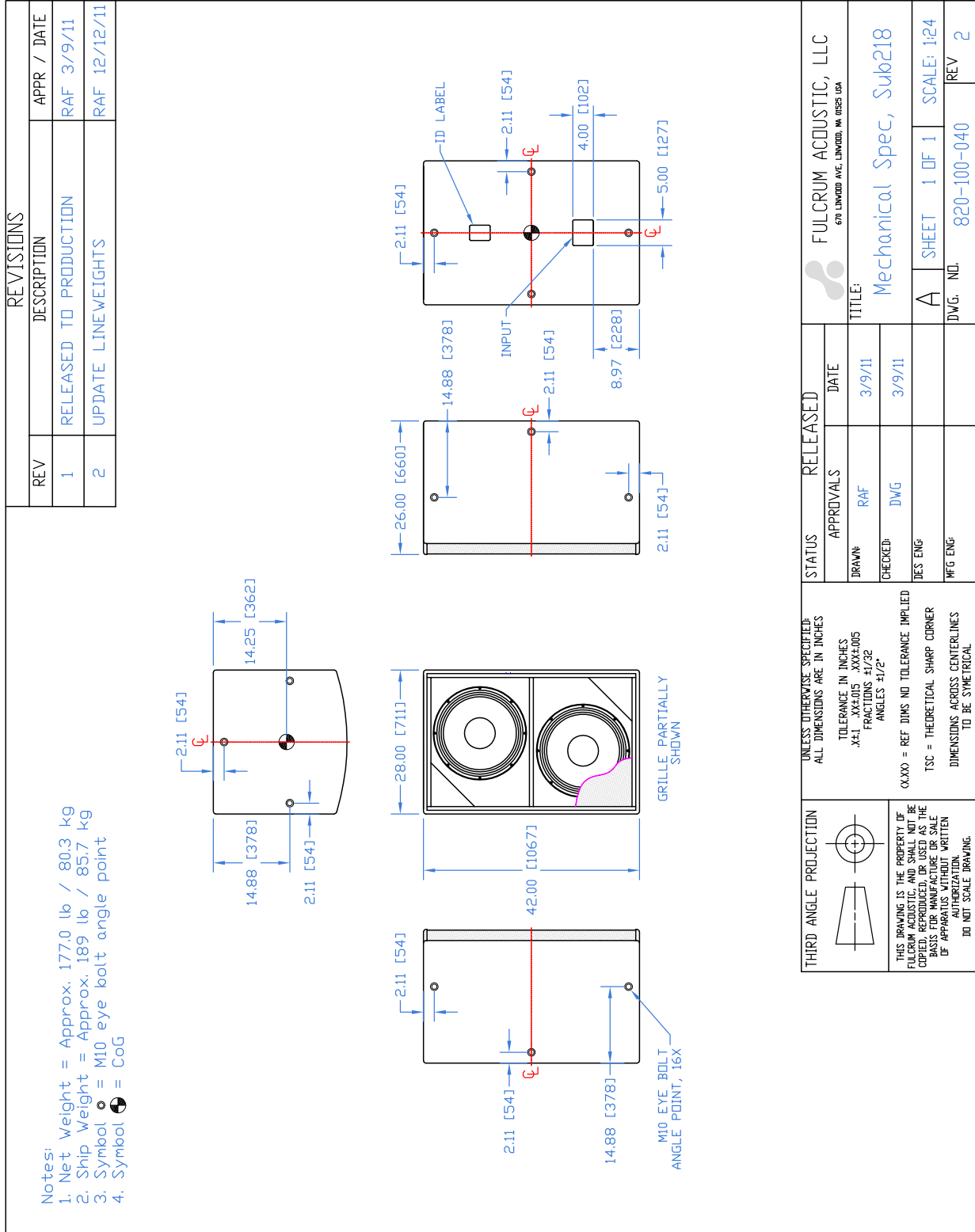

Drawing is reduced. Do not scale.