



RM25ac

Self-Powered Dual 15 inch Coaxial Reference Monitor

reference
MONITOR



Overview

The RM25ac is a bi-amplified, 3-way coaxial reference monitor that provides the accuracy, pristine imaging and precise transient response required of a studio monitor but with the directional control, power handling and output capability required in larger spaces. The coaxial and low frequency transducers are mounted in independent, asymmetrical chambers designed to minimize standing waves. In addition, the internal volume and porting are optimized for extended low frequency response. This combination results in a highly articulate low mid transient response and surprisingly visceral low frequency extension. The RM25ac is available both in the standard studio version, which includes four M6 mounting points for use with third-party isolation feet, and in an installation version which includes twelve M10 eye bolt points and two M10 yoke points. Its rotatable 90° x 45° coaxial transducer supports either vertical or horizontal orientation.

Sound, innovative acoustical design combined with on-board TQ™, Level 1 processing provides exceptional clarity and stability, and precise transient response even at very high sound pressure levels. Four back panel selectable presets optimize the response for either vertical or horizontal orientations, whole or half space. A full complement of input filters and delay, as well as signal levels and amplifier status, may be accessed via Ethernet, using **Armonia Pro Audio Suite™** control software. In addition, a pre-output EQ stage is available for programming custom presets. These presets may be saved and later recalled using the back panel Preset Select button or software.

The RM25ac's robust transducers are powered by two 1050 watt amplifier channels, designed and manufactured in Italy by Powersoft. Powersoft amplifiers incorporate state-of-the-art Class-D technology to produce extremely high efficiency, low noise, and low intermodulation distortion in compact and lightweight packages.

The RM25ac is primarily intended for use as a mid- to far-field monitor in recording studios and A/V production suites; but it is also an ideal choice for cinemas, museum exhibit spaces, multimedia presentation facilities, boardrooms, and high end home theaters: any environment in which pristine audio quality is desired and a protective grille is not necessary.

Performance Specifications¹

Operating Mode

Self-Powered, w/ On-Board DSP

Operating Range²

24 Hz to 20 kHz

Nominal Beamwidth (rotatable)

90° x 45°

Transducers

LF: 15.0" ceramic magnet woofer, 4.0" voice coil
HF/LF: Coaxial 3.0" titanium diaphragm compression driver;
15.0" woofer, 3.0" voice coil; single neodymium magnet

Power Handling @ Nominal Impedance³

LF: 75 V / 700 W @ 8 Ω

HF/LF: 57 V / 400 W @ 8 Ω

Nominal Sensitivity @ Input Voltage⁴ (whole space)

LF: 95 dB @ 2.83 V

HF/LF: 104 dB @ 2.83 V

Nominal Maximum Continuous SPL

LF: 123 dB

HF/LF: 130 dB

Equalized Sensitivity @ Input Voltage⁵

96 dB @ 2.83 V

Equalized Maximum SPL⁶

126 dB

Physical Specifications

Connections

(2) Neutrik NL4 Speakon

Pin 1+/-: LF

Pin 2+/-: HF/LF

Mounting / Suspension Points

Studio Version:

(4) M6 x 1.0 mounting points for user-supplied isolation feet

Installation Version:

(12) M10 x 1.5 suspension points, (2) M10 x 1.5 yoke points

Dimensions / Weight

See page 6

Finish

Black or white painted enclosure

Options

Custom color finish



product specification

Audio Input

Connectors

Analog In: Female XLR
Analog Out: Male XLR
AES3 In: Female XLR
Ethernet / AESOP: 2x 8P8C (RJ45)

Analog Input Wiring

Pin 1: Chassis
Pin 2: Signal +
Pin 3: Signal -

Input Impedance

10 k Ω balanced to ground

Input Sensitivity

1.5 Vrms / 6.0 dBu

Maximum Input Voltage

6.3 Vrms / 18.2 dBu

Controls

Preset Select: 1 thru 4, press and hold 3 sec to access 5 thru 8
Input Select: Analog, AES3 A, AES3 B, AES3 A+B
Input EQ: In / Out
Input Volume: Full clockwise = nominal gain

LED Indicators

Ready, signal, temp, limit, protect, selected preset,
selected input, input EQ in

Digital Signal Processing

DSP Encoding

24 bit / 48 kHz

DSP Latency

Analog Input: 3.52 ms

Input Processing (software accessible)

Three layers raised cosine parametric or graphic EQ
Filter Types: Peaking, asymmetrical, low and high shelf, low and high pass
Delay: 2 seconds
Gain
Polarity
Mute

Pre-Output Processing (software accessible)

Sixteen bands parametric EQ
Filter Types: Peaking, low and high shelf, low and high pass, band pass, band stop, all pass
Delay: 2 seconds
Gain
Mute

Amplifier

Type

Two-channel Class D

Output Power

EIAJ test, 1 kHz, 1% THD: 2x 1050 W @ 8 Ω
Maximum Output Voltage: 2x 129 V peak

Frequency Response

10 Hz to 25 kHz, ± 3 dB, for 1 W @ 8 Ω

S/N Ratio

> 112 dBA, 20 Hz to 20 kHz

Crosstalk Separation

> 70 dB @ 1 kHz

Slew Rate

50 V / microsecond @ 8 Ω , input filter bypassed

Damping Factor

> 500 @ 100 Hz

Distortion

THD+N: < 0.05% from 0.1 W to full power (typically < 0.01%)
SMPTE IMD: < 0.05% from 0.1 W to full power (typically < 0.01%)
DIM100 IMD: < 0.02% from 0.1 W to full power (typically < 0.005%)

Efficiency

> 80% (typical)

Cooling

Temperature-controlled variable speed internal fan

Maximum Operating Ambient Temperature

40° C

Protection Systems

Over-temp power limiting, thermal shutdown, short-circuit,
overload output protection

AC Mains

Connections

Mains In: Neutrik powerCON NAC3MPA
Mains Out: Neutrik powerCON NAC3MPB

Mains Voltage

100 to 240 V~, 50/60 Hz

Current Draw (1/8 max output power)

5.5 to 2.9 A

Thermal Emission (1/8 power @ 4 Ω)

282 BTU/h 71 kcal/h



product specification

Axial Sensitivity (dB SPL, 2.83 V @ 1 m)^{7,8}

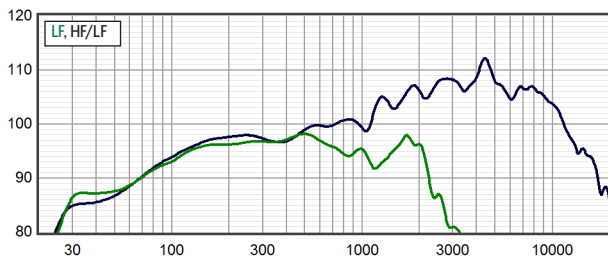

Horizontal Off Axis Response^{7,11}

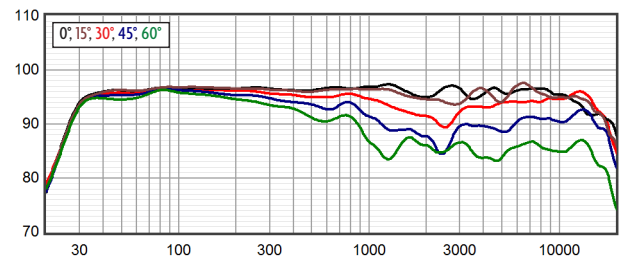

Axial Processed Response (dB)^{7,9}

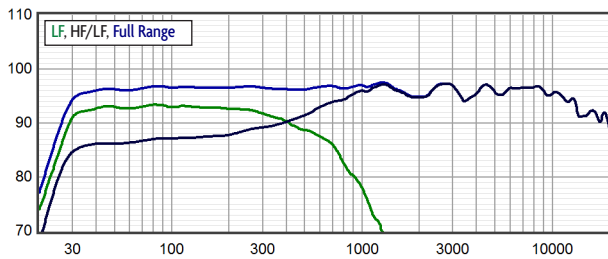

Vertical Off Axis Response^{7,11}

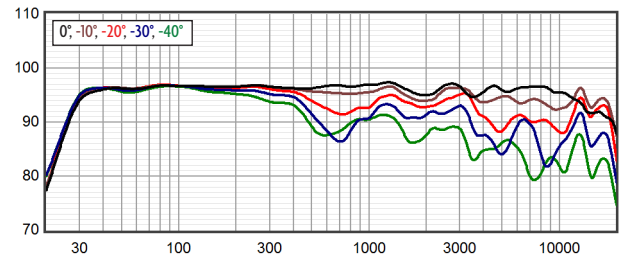

Axial Processed Phase Response (degrees)^{7,10}

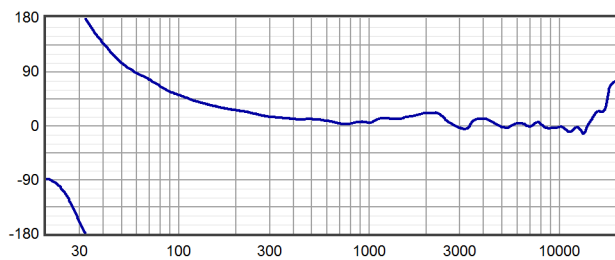

Beamwidth^{7,12}

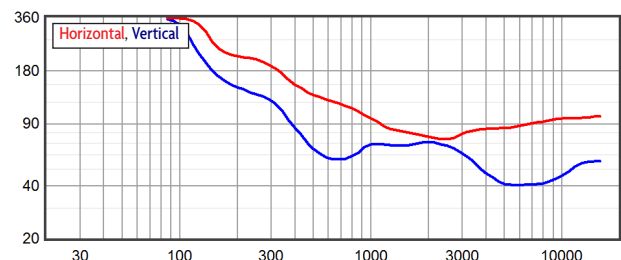

Impedance (ohms)

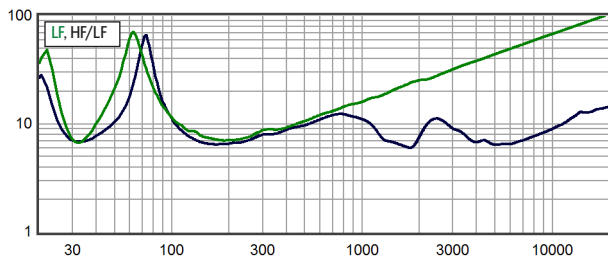

Directivity Index (dB)¹³

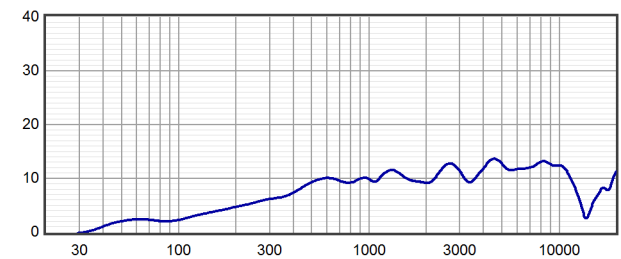



Horizontal Polar Response (30 dB Scale, 6 dB per Major Division)

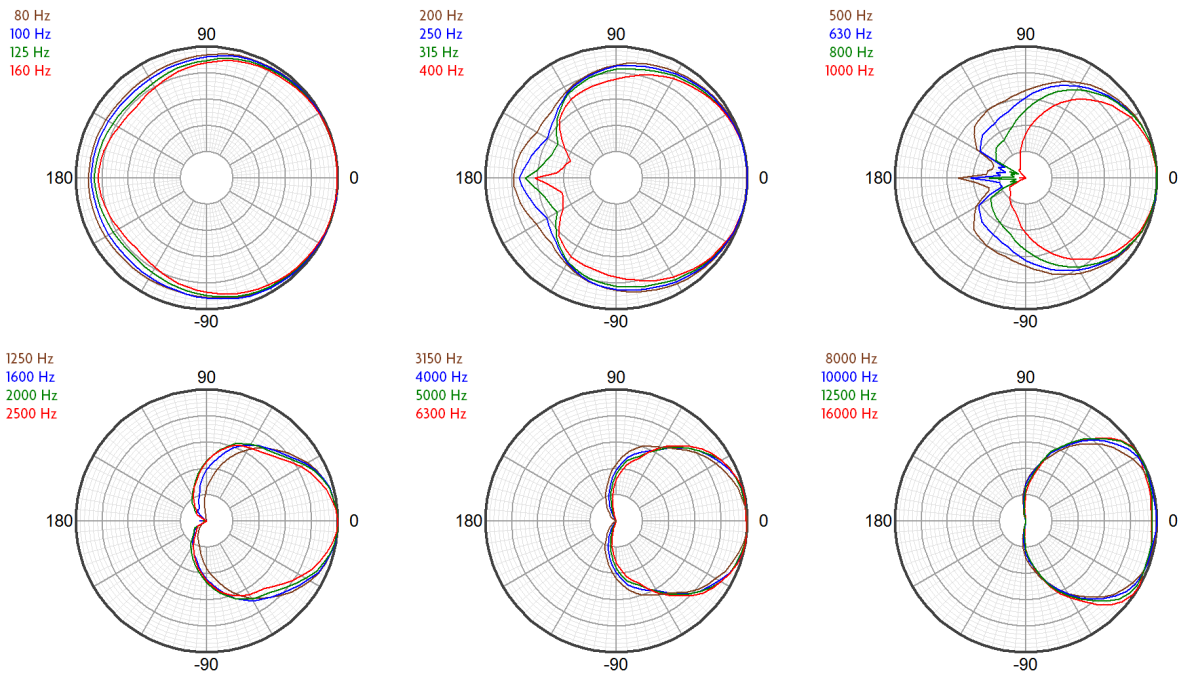

Vertical Polar Response (30 dB Scale, 6 dB per Major Division)

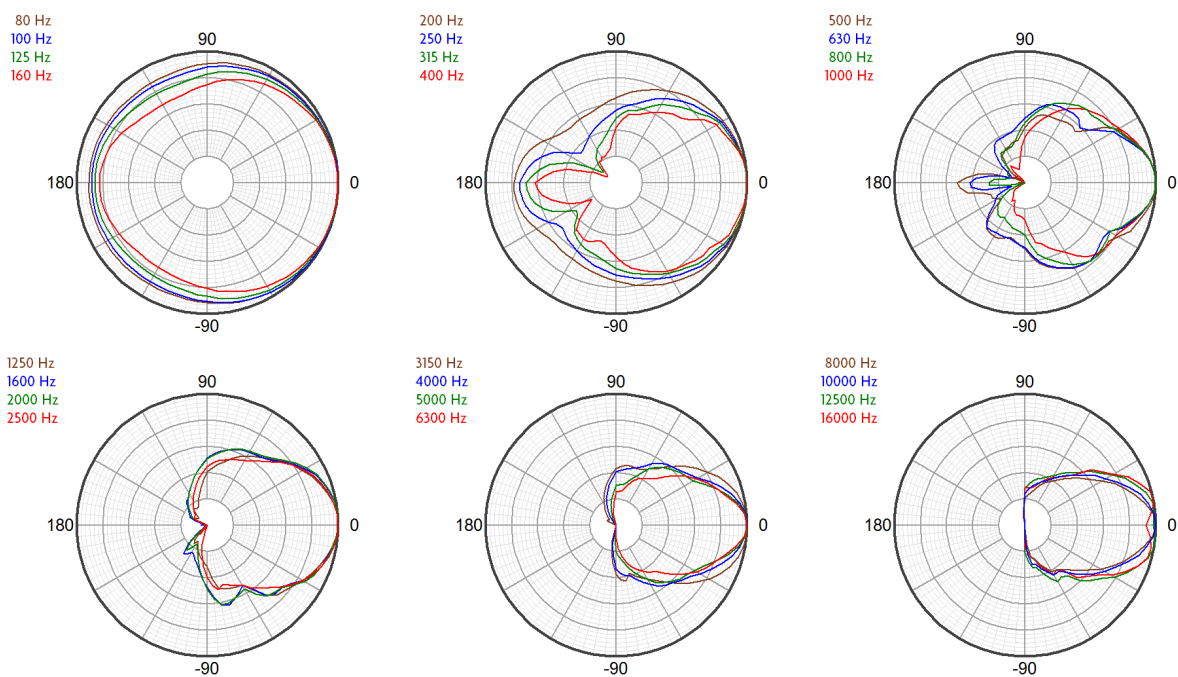



Technologies

The RM series represents a modern digital-signal-processing-aware update to the traditional horn-loaded coaxial monitor concept. The well-known benefits of the coaxial approach have been realized without the familiar shortcomings of historical designs. Fulcrum **Temporal Equalization™ (TQ™)** digital signal processing techniques provide precise transient response and accurate voicing, while ensuring smooth, seamless coverage through the crossover range. In fact, the coaxial transducers were designed from the ground up to take advantage of the unique capabilities of TQ™.

The coaxial transducer in the RM25ac includes a 3 inch diaphragm compression driver. The large diaphragm area permits the compression driver to operate at frequencies too low for smaller compression drivers to handle. This allows the high frequency horn to smooth the directional response of the low frequency section in the frequency range where the horn would otherwise cause shadowing. It also allows the compression driver to produce extreme sound pressure levels with an effortless sonic character.

The coaxial woofer's large radiating surface works in conjunction with the high frequency horn to improve directional control at the low frequency end of the horn's operating range, increasing directional control beyond what can be accomplished by the horn alone.

Input Panel

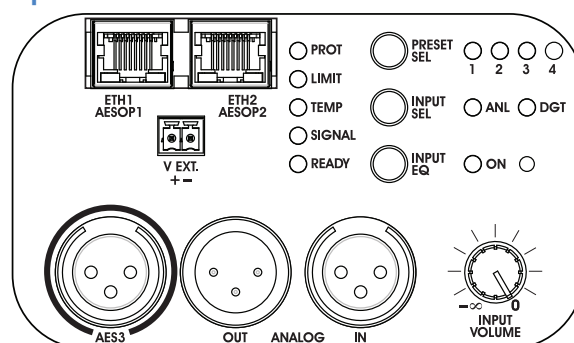

RM25ac Presets

Preset 1	Vertical Orientation, Whole Space
Preset 2	Vertical Orientation, Half Space
Preset 3	Horizontal Orientation, Whole Space
Preset 4	Horizontal Orientation, Half Space

Presets 5-8 user-programmable in **Armonia Pro Audio Suite™** control software. Press and hold rear panel Preset Select button 3 seconds to access these presets.

Mechanical Specification Drawings

2D and 3D DXF dimensional drawings are available for download at www.fulcrum-acoustic.com/support.

Notes

- ¹ **Performance Specifications** All acoustic specifications rounded to nearest whole number. External DSP with Fulcrum Acoustic-provided settings is required to achieve the specified performance.
- ² **Operating Range** The frequency range within which the processed response is within 10 dB of the average.
- ³ **Power Handling** Based on the AES power handling of the transducers.
- ⁴ **Nominal Sensitivity** The 1-meter-referenced SPL produced by a 1 watt band limited pink noise signal, with no processing applied.
- ⁵ **Equalized Sensitivity** The 1-meter-referenced SPL produced when an EIA-426-B signal is applied to an equalized loudspeaker system, at a level which produces a total power of 1 watt, in sum, to the loudspeaker subsections.
- ⁶ **Equalized Maximum SPL** The 1-meter-referenced SPL produced when an EIA-426-B signal is applied to an equalized loudspeaker system, at a level which drives at least one subsection to its rated power.
- ⁷ **Resolution** All response graphs are subjected to 1/6 octave cepstral smoothing with a gaussian weighting function.
- ⁸ **Axial Sensitivity** The SPL plotted against frequency for a 1 watt swept sine wave, referenced to 1 m with no signal processing.
- ⁹ **Axial Processed Response** The axial magnitude response with recommended signal processing applied.
- ¹⁰ **Axial Processed Phase Response** The axial phase response with recommended signal processing applied, and latency removed.
- ¹¹ **Horizontal / Vertical Off Axis Responses** The magnitude response at various angles off axis, with recommended signal processing applied.
- ¹² **Beamwidth** The angle between the -6 dB points in a loudspeaker's polar response.
- ¹³ **Directivity Index (Di)** The ratio of the on-axis sound pressure squared to the spherical average of the sound pressure squared at a particular frequency expressed in dB. To convert the directivity index to directivity factor (Q) use the formula $10^{Di/10}$.



product specification

Notes:

1. Net Weight = Approx. 117.0 lb / 53.1 kg
2. Ship Weight = Approx. 132.0 lb / 59.9 kg
3. Symbol = M6 FOOT mounting point (user-supplied)
4. Symbol = CoG

REVISIONS		
REV	DESCRIPTION	APPR / DATE
1	NEW ISSUE	DEW 3/22/18
2	RE-ORIENT DRAWING	RAF 7/12/18

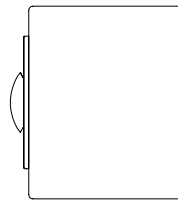

TOP

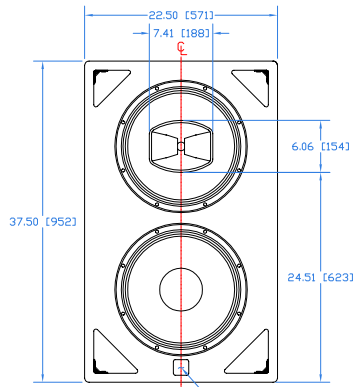

FRONT

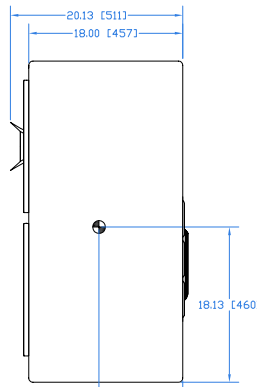

SIDE

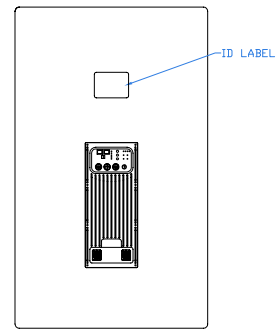

REAR

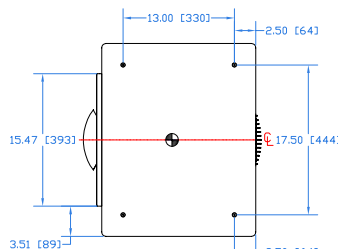

BOTTOM

<p>THIRD ANGLE PROJECTION</p>	<p>UNLESS OTHERWISE SPECIFIED: ALL DIMENSIONS ARE IN INCHES</p> <p>TOLERANCE IN INCHES .XX±.015 .XXX±.005 FRACTIONS ±1/32 ANGLES ±1/2°</p> <p>(X.XX) = REF DIMS NO TOLERANCE IMPLIED</p> <p>TSC = THEORETICAL SHARP CORNER</p> <p>DIMENSIONS ACROSS CENTERLINES TO BE SYMMETRICAL</p>	<p>STATUS RELEASED</p>		<p>FULCRUM ACOUSTIC, LLC 670 LINWOOD AVE, LINWOOD, MA 01525 USA</p>
		<p>APPROVALS</p> <p>DATE</p>	<p>DATE</p>	
<p>THIS DRAWING IS THE PROPERTY OF FULCRUM ACOUSTIC, AND SHALL NOT BE COPIED, REPRODUCED, OR USED AS THE BASIS FOR MANUFACTURE OR SALE OF APPARATUS WITHOUT WRITTEN AUTHORIZATION. DO NOT SCALE DRAWING.</p>		<p>DRAWN: DEW</p>	<p>03/22/18</p>	<p>Mechanical Spec, RM25ac Studio</p>
		<p>CHECKED:</p>		<p>B SHEET 1 OF 1 SCALE: 1:20</p>
		<p>DWG. NO. 820-100-119</p>	<p>REV 2</p>	

Drawing is reduced. Do not scale.



product specification

Notes:

1. Net Weight = Approx. 117.0 lb / 53.1 kg
2. Ship Weight = Approx. 132.0 lb / 59.9 kg
3. Symbol = M10 eye bolt angle point
4. Symbol = M10 nut plate
5. Symbol = CoG

REVISIONS		
REV	DESCRIPTION	APPR / DATE
1	NEW ISSUE	DWG 6/05/13
2	ADD BADGE RECESS TO BAFFLE	RAF 4/11/14
3	UPDATE TITLE TO "INSTALL"	RAF 7/12/18

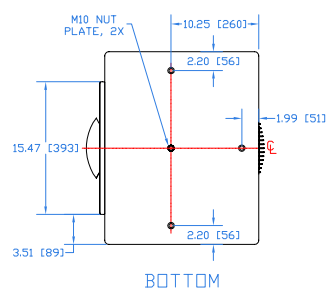
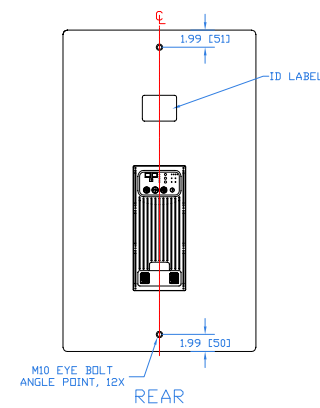
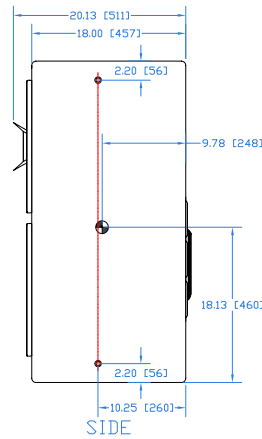
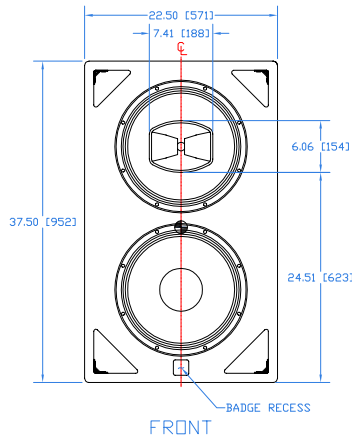
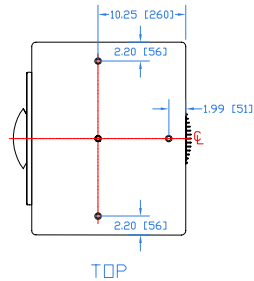

THIRD ANGLE PROJECTION

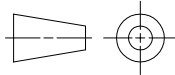

THIS DRAWING IS THE PROPERTY OF FULCRUM ACOUSTIC, AND SHALL NOT BE COPIED, REPRODUCED, OR USED AS THE BASIS FOR MANUFACTURE OR SALE OF APPARATUS WITHOUT WRITTEN AUTHORIZATION. DO NOT SCALE DRAWING.

UNLESS OTHERWISE SPECIFIED: ALL DIMENSIONS ARE IN INCHES

TOLERANCE IN INCHES
.X+1 .XX±.015 .XXX±.005
FRACTIONS ±1/32
ANGLES ±1/2°

(X.XX) = REF DIMS NO TOLERANCE IMPLIED

TSC = THEORETICAL SHARP CORNER

DIMENSIONS ACROSS CENTERLINES TO BE SYMMETRICAL

STATUS RELEASED

APPROVALS	DATE
DWG	6/05/13
CHECKED: RAF	6/05/13
DES' ENG:	
MFG ENG:	



FULCRUM ACOUSTIC, LLC
670 LINWOOD AVE, LINWOOD, MA 01525 USA

TITLE: Mechanical Spec, RM25ac Install

B	SHEET 1 OF 1	SCALE: 1:20
DWG. NO.	820-100-068	REV 3

Drawing is reduced. Do not scale.